

THREE-PHASE INDUCTION MOTORS OF THE SERIES PM FOR COOLING MICROTOWERS

APPLICATION

Three-phase low-speed induction motors of the series PM are intended for the drives of axial-flow fans for cooling microtowers without gears, both for new cooling microtowers and for the repairs of the existing ones. A direct drive of the fan by a low-speed motor has significant advantages in comparison with a usual solution with a high-speed motor connected with a gearbox:

- no gearbox with an oil system, which is important because of the environment protection (the cooling agent cannot be polluted by oil)
- considerably longer service life of the whole fan drive
- lower noise and vibration levels
- lower assembly costs
- no maintenance for the whole service life period

The motors are designed for a possibility of the speed-changing ratio 2 : 1 (Dahlander-type winding connection), enabling thus a more economical adjustment of the cooling power of a microtower in different climatic conditions.

The motors are designed for humid environment corresponding to the conditions of cooling microtowers - relative humidity up to 100 % at 25 °C, temperature of moist air being delivered (forming at the same time the cooling agent removing heat losses from the motor surface) up to + 40 °C.

TECHNICAL PARAMETERS

TYPE	PM	PM 4,8-584D	PM 8-485D
Power output	P [kW]	4,8 / 0,95	8 / 1,4
Speed	n [min ⁻¹]	585 / 292	485 / 242
Pole number	2p [-]	10 / 20	12 / 24
Rated torque	Mn [Nm]	78 / 31	157 / 55
Rated voltage	U _{1n} [V]	3 AC 400	
Frequency	f [Hz]	50	
Connection	-	YY / Y	
Rated current	I _{1n} [A]	9,9 / 3,3	16,5 / 5,2
Efficiency	[%]	85 / 75	86 / 75
Power factor	cos [-]	0,80 / 0,54	0,80 / 0,50
Short-circuit current	I _k [A]	49,5 / 10,8	82,5 / 15,4
Short-circuit torque	M _k [Nm]	74 / 26	129 / 48
No-load current	I _o [A]	4 / 2,5	12 / 4,2
Moment of inertia of the rotor	J [kgm ²]	0,48	0,7
Mass of the machine	G [kg]	150	185

Motors with different values of the power output, rated voltage and speed may be delivered on request.

DESIGN

- The motors have ribbed frame, cast from Al alloy, which contributes to a low mass and provides for an efficient motor cooling.
- The rotor is mounted in antifriction bearings with permanent grease filling. The motors do not require any maintenance for the whole service life period which is at least 70 000 running hours.

- The motors are made in the form IM 3011, i.e. the motor is mounted in a vertical position with the downward free shaft end on which the fan hub is being mounted. They may be delivered also in the form IM 3001. The motor is designed for axial and radial loads from the axial-flow fan being driven. The free shaft end is provided with a work centre with a thread M20.
- The end windings are fitted with embedded PTC posistors for thermal protection. The posistors are connected to separate terminals in the terminal box.
- The degree of protection of the motors is IP54; cooling method IC 48; insulation class F (utilization in the class B).

BASIC DIMENSIONS

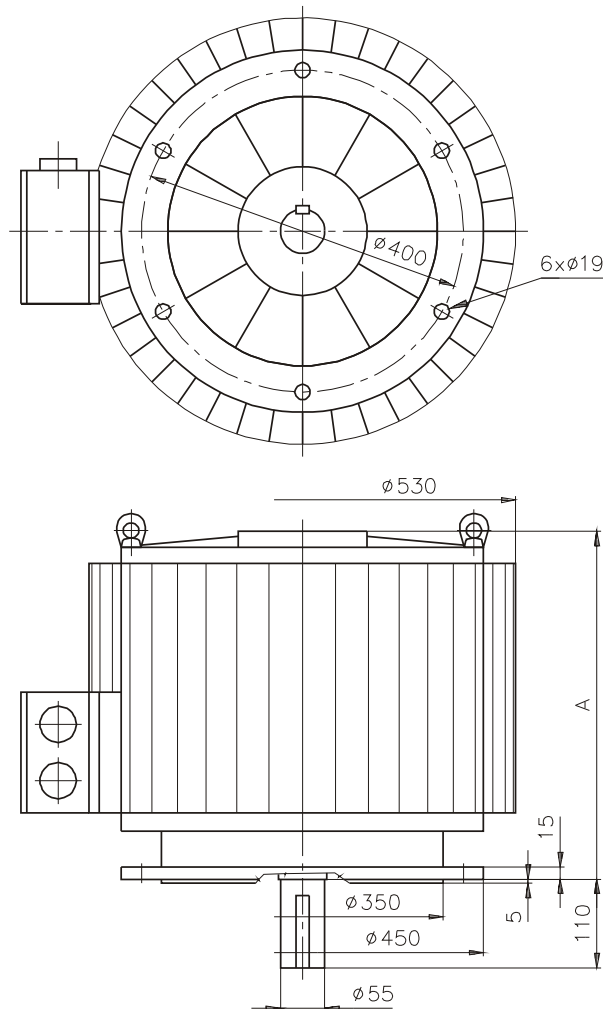

All dimensions in mm.
 Key dimensions are 16 x 10 mm.
 Both motor types have different heights A.

Motor type	Dimension A [mm]
PM 4,8-584D	440
PM 8-485D	480

Note: The motor may be made without a terminal box, only with outlet cables of the length according to the requirement of the customer.